

**DEPARTMENT OF MECHANICAL ENGINEERING
BANGLADESH UNIVERSITY OF ENGINEERING AND TECHNOLOGY, DHAKA.**

Applied Mechanics and Material Laboratory

ME-346: MECHANICS OF MACHINERY SESSIONAL

Mechanical engineers deal with machines. Machines consist of different parts and/or links connected together in such a way that for a given input (motion or force) a desired output (motion or force) is obtained. In order to know the characteristics of a machine, one should know the behaviour of a body in motion with or without reference to forces involved. In Mechanics of Machinery Sessional, students are urged to familiarize themselves with various properties of bodies in motion. They should also be able to solve numerical problems.

The following experiments are to be done in one term:

Set. No.	Expt. No.	Name of the Experiment
1	1	Static and Dynamic Balancing of a Shaft
1	2	Bifilar Suspension
2	3	Free Vibration of a Single Degree of Freedom System
2	4	Determining Mass Moment of Inertia of a Flywheel
3	5	Study of Compound Pendulum
3	6	Study of Gyroscope
4	7	Critical Speed of a Shaft
4	8	Study of Cam

YOU MUST READ THE INSTRUCTIONS CAREFULLY BEFORE COMING TO THE CLASS.

Submission of Reports:

The students must submit their reports at the end of the class. Reports should be brief and must be submitted in a file. Name of the student, roll number, group and session should be clearly written on the top cover of the file as well as on the top sheet of each set of experiments.

For ease of identification, each group of students should use coloured files as recommended by the teachers.

The report should include the following items:

1. Set number and experiment number
2. Name of the experiment
3. Objectives of the experiment
4. Names (only) of the apparatus
5. Schematic diagram of the experimental set-up
6. Experimental data
7. Sample calculations
8. Graphs and results
9. Discussions

NOTE: Items I through 5 should be prepared by each student before coming to perform experiments.

Each student must bring with him SCALE, PEN, PENCIL, ERASER, GEOMETRY / INSTRUMENT BOX, PLAIN PAPERS, GRAPH PAPERS, etc.

EXPERIMENT NO. 1

STATIC AND DYNAMIC BALANCING OF A SHAFT

OBJECTIVES:

1. To calculate angular and longitudinal positions of counter balancing weights for static and dynamic balancing of an unbalanced rotating mass system.
2. To check experimentally that the positions of counter balancing weights calculated as above are correct.

THEORY:

A shaft is said to be statically balanced if the shaft can rest, without turning, at any angular position in its bearings. This condition is attained when the sum of the centrifugal forces on the shaft due to unbalanced masses is zero in any radial direction. The centrifugal force due to unbalanced mass of weight W_i with its centre of gravity at a radial distance r_i is proportional to $W_i r_i$. For a shaft to be statically balanced, the summation of components of all such forces should be zero in any radial direction. That is,

$$\sum_i W_i r_i = 0$$

A shaft is said to be dynamically balanced when it does not vibrate in its running state. To make a shaft dynamically balanced, it must first be statically balanced. In addition, the sum of the moments of centrifugal forces due to the attached masses about any axis perpendicular to the axis of the shaft must be zero. This condition is fulfilled when

$$\sum_i W_i r_i l_i = 0$$

where l_i is the distance of the attached mass from one end of the shaft.

APPARATUS:

Static and dynamic balancing machine.

The machine consists of two frames - a small rectangular main frame and a large rectangular support frame which stands vertically up on a platform. The shaft to be balanced is mounted in the main frame and may be run by an electric motor attached to the lower member of the frame. The axial distance of the masses can be measured by a scale attached to the lower member. The position of masses is determined with the help of a protractor fitted to one end of the shaft. Four different masses are provided which may be clamped on to the shaft at any axial and angular positions.

PROCEDURES:

A. STATIC BALANCING

1. Clamp blocks 1 and 2 on to the shaft at given (known) angular positions and at any convenient axial positions. The shaft becomes statically unbalanced. See figure below.

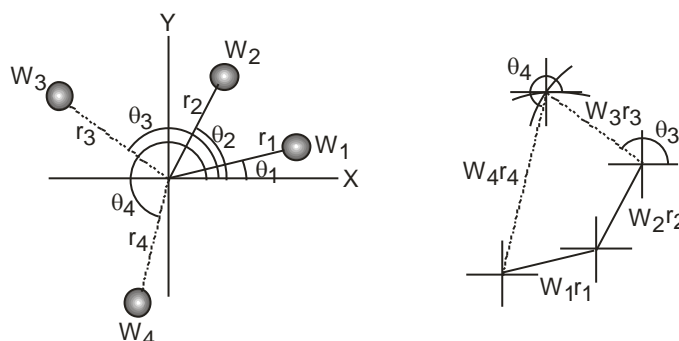

2. To balance the shaft, blocks 3 and 4 are to be clamped at some angular positions which will satisfy the following equations for static balancing;

$$\sum_c (W_i r_i)_x = \sum_t (W_i r_i) \cos \theta_i = 0$$

$$\sum_t (W_i r_i)_y = \sum_t (W_i r_i) \sin \theta_i = 0$$

The angular positions of blocks 3 and 4 can be found from the above equations. Knowing the Wr -values of the four blocks, one should be able to find the unknown angles with the help of the force polygon.

3. Clamp blocks 3 and 4 on the shaft at the determined angles.
4. They should be statically balanced. Verify that the shaft rests in its bearings at any angular positions.

B. DYNAMIC BALANCING:

1. Take the main frame off from its rigid support and suspend it parallel to the support frame with the help of three springs. Put on the motor belt.
2. Place blocks 1 and 2 at given axial and radial positions. Radial positions being calculated earlier, axial positions of blocks 3 and 4 have to be determined for dynamic balancing analytically by using the following equations or graphically by using the couple polygon;

$$\sum_c (W_i r_i l_i)_x = \sum_t (W_i r_i \sin \theta_i) L_i = 0$$

$$\sum_c (W_i r_i l_i)_y = \sum_t (W_i r_i \cos \theta_i) L_i = 0$$

Let their axial positions be indicated by L_3 and L_4 as required for dynamic balancing.

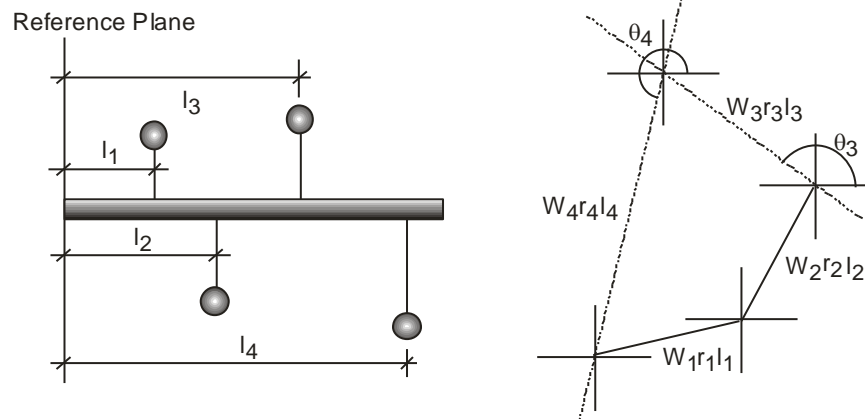

3. Clamp locks 3 and 4 at the calculated angular and axial positions.
4. Switch on the motor to run the shaft and verify that the shaft does not vibrate.

DISCUSSIONS:

1. While verifying the stages of balancing experimentally did you notice any deviation from the ideal state? What were the deviations?
2. State the reasons for deviations if there were any.
3. Why dynamic balancing is so important to us?
4. Is the effect of unbalance of the shaft the same at all speeds of the shaft? If not, what is the most dangerous speed?

EXPERIMENT NO. 2 BIFILAR SUSPENSION

OBJECTIVES:

The objectives of the experiment are to determine experimentally the moment of inertia and the radius of gyration about its centre of gravity and to compare them with theoretical values.

THEORY:

The bifilar suspension is used to determine the moment of inertia of a body about an axis passing through its centre of gravity. The body is suspended by two parallel cords of length “ ℓ ”, at a distance “ d ” apart. If the mass of the body is “ M ”, then the tension in either cord is $Mg/2$. If the system is now displaced through a small angle θ at its central axis, then an angular displacement ϕ will be produced at the supports (see figure below).

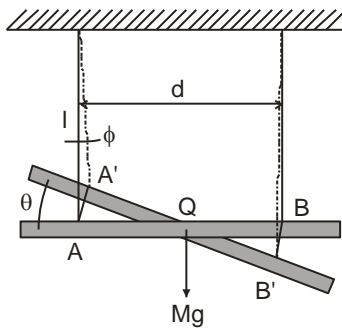

If both angles are small, then $\ell\phi = \left(\frac{d}{2}\right)\theta$

The restoring force at the point of attachment of the thread B and B_1 will be –

$$\frac{Mg}{2} \sin \phi = \frac{Mg}{2} \phi \quad (\text{for small } \phi)$$

Since $\phi = \left(\frac{d\theta}{2\ell}\right)$, the restoring force = $Mg \frac{d\theta}{4\ell}$, and the restoring couple is thus $-Mgd \frac{d\theta}{4\ell}$.

Giving an equation of motion $I\ddot{\theta} = \frac{-Mgd^2 \cdot \theta}{4\ell}$ i.e., $\ddot{\theta} + \frac{Mgd^2 \cdot \theta}{4I\ell} = 0$

Therefore, the motion is S.H.M. of periodic time, $T = 2\pi \sqrt{\frac{4I\ell}{Mgd^2}}$

Therefore, $I = \frac{mgd^2 T^2}{16\pi^2 \ell}$

Alternatively, T may be expressed as: $T = 2\pi \cdot \frac{2K}{d} \sqrt{\frac{\ell}{g}}$, since $K^2 = \frac{I}{M}$

where d is the distance between the wires (m)

ℓ is the length of suspension (m)

K is the radius of gyration of the body about its centre of gravity.

APPARATUS:

The Universal Vibration Apparatus and a uniform rectangular bar suspended by fine wires.

PROCEDURES:

Suspend the beam by wires and adjust it to some suitable length l . Measure the distance between the threads “ d ” accurately, before displacing the beam through some small angle. Measure time for 20 oscillations, from which the periodic time may be calculated. Repeat the procedure three times.

Change the length of the wires l and time a further 20 swings. The periodic times should be calculated for four such lengths. The inertia of the body may be increased by placing the two masses on either side of the centre line, and repeating the procedure four times for various values of l and b (b being the distance of separation of the masses). Having determined the parameters l , b , d and T , the radius of gyration K may be calculated from:

$$T = \frac{4\pi K}{d} \sqrt{\frac{I}{g}}, \text{ from which } K = \frac{Td}{4\pi} \sqrt{\frac{g}{I}}$$

In order to calculate moments of inertia, the mass of the beam (unloaded) is required.

DATA AND RESULTS:

The data should be presented in a tabular format like the sample table shown below:

Test No.	I (m)	d (m)	T (S)	K (m)	K^2 (m ²)	M (kg)	I (kg-m ²)

DISCUSSIONS:

1. How would one determine the radius of gyration, and hence moment of inertia, of any body using the bifilar suspension?
2. Are the theoretical and experimental values of K and I in good agreement? If not so, what may be the reason(s)?

EXPERIMENT NO. 3 FREE VIBRATION OF A SINGLE DEGREE OF FREEDOM SYSTEM

OBJECTIVES:

To determine the frequency of small vibration of a pendulum by theoretical and experimental means.

THEORY:

A. FREE VIBRATION WITHOUT SPRINGS

Let ϕ be the angle of inclination and l be the length of the bar, W be the weight of the pendulum (refer to the figure below). Assume that the weight of the bar is negligibly small.

Then, for any angular displacement ϕ , of the pendulum.

Kinetic Energy (K.E.) = $[W(\omega l)^2/2g]$, where ωl is the velocity of the pendulum.

Change in potential energy due to vertical displacement is –

$$Wl(1-\cos\phi) = Wl \frac{\phi^2}{2}$$

Therefore, the total energy for the set-up is

$$\frac{W(\omega l)^2}{2g} + Wl \frac{\phi^2}{2} = \text{constant}$$

$$\text{i.e., } \omega^2 + \frac{\phi^2 \cdot g}{l} = \text{constant} \Rightarrow \frac{d^2\phi}{dt^2} + \frac{g\phi}{l} = 0$$

The frequency of vibration is $\omega = \sqrt{g/l}$ and the time period

$$T = \frac{2\pi}{\omega} = \frac{2\pi}{\sqrt{g/l}}$$

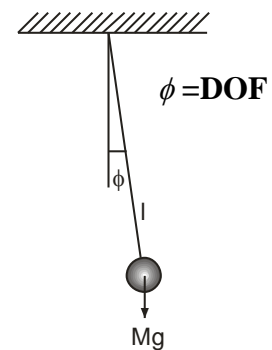

B. FREE VIBRATION WITH SPRINGS

If the spring constants of the two springs are K_1 and K_2 respectively, then the equivalent spring constant (see figure) should be

$$K = K_1 + K_2$$

The kinetic and the potential energies are the same as those in the case of the set-up without spring. The strain energy for the springs is –

$$\frac{1}{2} K \delta^2 = \frac{K}{2} (a\phi)^2 \quad \text{since } \delta = a\phi$$

Therefore, the total energy of the system is –

$$\frac{W(\omega l)^2}{2g} + Wl \frac{\phi^2}{2} + \frac{K}{2} (a\phi)^2 = \text{constant}$$

$$\omega^2 + \left(\frac{g}{l} + \frac{Kga^2}{Wl^2} \right) \phi^2 = \text{constant}$$

$$\text{Then frequency } \omega = \sqrt{\frac{g}{l} + \frac{Kga^2}{Wl^2}} \text{ and period } T = \frac{2\pi}{\omega} = \frac{2\pi}{\sqrt{\frac{g}{l} + \frac{Kga^2}{Wl^2}}}$$

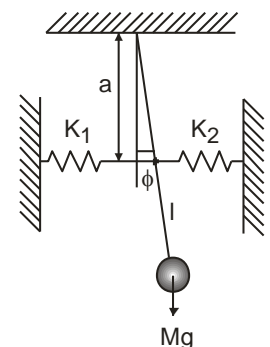

APPARATUS:

1. Measure W and ℓ . The values of spring constants are given below.
2. Displace the pendulum through a small angle and let go. Record the time for 20 oscillations. Repeat the procedure at least thrice and calculate the average frequency without springs.
3. Repeat step 3 for at least two more values of a .
4. compare the experimentally found frequencies with the theoretical ones.

DATA AND RESULTS

Weight of the pendulum, $W = 1.5$ lb.
 Length of the bar, $l = 18.5$ inch.
 Spring constant for spring 1, $K_1 = 3.3$ lb/in
 spring constant for spring 2, $K_2 = 3.3$ lb/in
 Equivalent spring constant, $K = 6.6$ lb/in
 Length, $a =$

Sample data sheet for the experimental set-up without springs:

No. of Obs.	Time for 20 oscillations (sec.)	Average time for 20 oscillations (sec.)	Experimental frequency	Theoretical frequency

Sample data sheet for the experimental set-up with springs:

No. of Obs.	Length a (mm)	Time for 20 oscillations (sec.)	Average time for 20 oscillations (sec.)	Experimental frequency	Theoretical frequency

DISCUSSIONS:

Write down the reasons for the variations in the experimental and theoretical values, if there is any.

EXPERIMENT NO. 4 DETERMINING MASS MOMENT OF INERTIA OF A FLYWHEEL

OBJECTIVES

The objectives of the experiment are as follows:

1. To determine the mass moment of inertia of a flywheel by falling weight method.
2. To determine the radius of gyration.
3. To determine the frictional torque.

THEORY

Notations used:

α angular acceleration m attached mass T_t theoretical torque t time of fall a linear acceleration k radius of gyration	d diameter of the shaft with allowance for the rope T torque T_f frictional torque h height of fall I mass moment of inertia M mass of the flywheel
---	--

Governing equations:

$$T = I\alpha \quad (1)$$

$$T = T_t - T_f \quad (2)$$

$$T_t = (mg - ma) (d/2) \quad (3)$$

$$h = \frac{1}{2} (at^2) \quad (4)$$

$$a = \frac{2h}{t^2} \quad (5)$$

$$\alpha = \frac{2a}{d} \quad (6)$$

$$I = Mk^2 \quad (7)$$

$$k = \sqrt{I/M} \quad (8)$$

In the above equations, values of m , t , h , g , and d are known and T , T_t , T_f , a , and I are unknown.

$$T_t - T_f = I(2a/d)$$

$$\Rightarrow (mg - ma) \frac{d}{2} - T_f = I \cdot \frac{2}{d} \cdot \frac{h}{t^2} \quad [\text{from eqns. (3) and (5)}]$$

$$\Rightarrow m(g - 2h/t^2) d/2 - T_f = 4hI/dt^2$$

$$\Rightarrow m(gt^2 - 2h) d/2 - T_f t^2 = 4hI/d$$

$$\Rightarrow m(gt^2 - 2h) = \frac{2T_f t^2}{d} + \frac{8hI}{d^2}$$

In the above equation, the only variables are m and t . Note that the above equation is of the form

$$y = mx + c$$

where $m(gt^2 - 2h)$ is one variable on the ordinate, t^2 is the other variable on the abscissa and $2T_f/d$ is the slope. Therefore, if one draws a graph with these axes, one can obtain the value of T_f from the slope, and the value of I from the intercept on the ordinate. Once the moment of inertia becomes known, the radius of gyration can be calculated from eqn. (8).

APPARATUS

The test rig, stop watch, scale, mass holder and masses.

The test rig consists of a shaft resting on two ball bearings. The flywheel is mounted on the shaft. An inextensible cord carrying a mass holder is tied and wrapped around the shaft. One or more masses can be placed on the mass holder. If the load is sufficient to overcome the bearing friction, the cord unwinds from the shaft and the mass starts falling until stopped by a steel plate at the base.

PROCEDURE

1. Place the 0.964 kg weight on the holder. Turn the flywheel to wound the cord until the weight is at a height 1.473 metres.
2. Release the flywheel and start the stop watch simultaneously. The weight will start falling. Measure the time of fall. Repeat the step at least thrice. Calculate the average time of fall. (Accurate timing is very important in this experiment.)
3. Gradually increase the weight and repeat step 2 for at least 6 different weights. Always keep the height at 1.473 metres. (Suggested weights are 0.964, 1,490, 2,490, 4,830 and 9,500 kg).
4. Plot a graph with $m(gt^2-2h)$ along the ordinate and t^2 along the abscissa. The graph should be a straight line. From the graph, find the intercept on the ordinate and calculate the mass moment of inertia from the following formula:

$$I = d^2/8h \times (\text{Intercept on the ordinate})$$

5. Calculate the radius of gyration from the value of I.
6. Find the slope of the line and hence the friction torque by using the following formula:

$$T_f = \left(\frac{d}{2}\right) * (\text{slope})$$

DATA AND RESULTS

M = 15.391 kg
d = 0.032 m
h = 1.473 m
mass of the holder, $m_1 = 0.45$ kg

Sample data sheet:

No. of Obs.	Attached mass, m_2 (kg)	Total mass, $m = (m_1+m_2)$	Time of fall (sec.)			Average time of fall (sec.)	t^2	$m(gt^2-2h)$

DISCUSSIONS

The graph you have drawn should be a straight line. If it is not, state reasons. State any other points you find necessary to be stated.

EXPERIMENT NO. 5 STUDY OF COMPOUND PENDULUM

OBJECTIVES

The objectives of the experiment are to find out the radius of gyration and the moment of inertia of a compound pendulum and compare the experimental values with the theoretical values.

THEORY

When a rigid body, suspended from a point (as shown in the figure), is displaced through a small angle θ , the restoring couple- $Mgh \sin \theta = -mgh\theta$ (for small θ) is produced. The equation of motion is –

$$- mgh\theta = I\ddot{\theta} \quad (1)$$

where, $M =$ mass of the rod
 $h =$ distance of the centre of gravity from the point of suspension
 $\theta =$ angle of vertical displacement
 $I =$ moment of inertia for the rod about the axis through the point of suspension
 $\ddot{\theta} =$ acceleration of the system

The motion is simple harmonic and the periodic time, T is –

$$T = 2\pi\sqrt{(I / Mgh)} \quad (2)$$

If I_g is the moment of inertia about c.g. then

$$I = I_g + Mh^2 \text{ (according to the parallel axis theorem)} \quad (3)$$

$$\text{and } I_g = Mk^2 \quad (4)$$

where, K is the radius of gyration. Therefore,

$$T = 2\pi\sqrt{\frac{K^2 + h^2}{gh}}$$

By varying the value of h and evaluating T , the radius of gyration of the rod about its centre of gravity may be calculated and compared with the theoretical value.

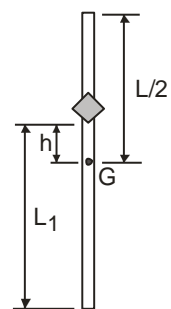

APPARATUS

The compound pendulum consists of a 12.7 mm diameter steel rod 0.914 m long. The rod is supported by an adjustable knife edge on the cross member. The knife edge can be moved along the rod to alter the value of h , i.e., the distance of the c.g. from the point of suspension.

EXPERIMENTAL PROCEDURE

The centre of gravity of the rod is measured from the given length of the rod. The position of the c.g. is at a distance of $(L/2)$ from either end, where L is the length of the rod. The knife edge is tightened at a given position so that it swings freely without any rotation at the support. The time for 30 oscillations is taken after displacing the pendulum through a small vertical angle. The time of 30 oscillations are recorded at least three times at any given value of L_1 . The average of these values gives the periodic time T .

Repeat the whole procedure to find out the periodic time T for each of the SEVEN different values of h . IT IS ADVISABLE TO REMOVE THE ROD FROM THE CROSS BEAM AND DO ANY ADJUSTMENTS AWAY FROM THE PORTAL FRAME.

The values of K can be calculated from the values of h and T from equation (5). These values are then compared with the theoretical values calculated from –

$$K = L_1/\sqrt{3} \text{ (Routh's Rule)}$$

DATA AND RESULTS

Length of the rod = 0.914 m

Diameter of the rod = 12.7 mm

Mass of the rod = 894.6 gm

Format of the Table:

No. of Obs.	Effective Length L_1 (m)	Value of h (m)	Time of 30 oscillations (sec)				Periodic Time T (sec)	Expt. value of K (m)	Theoretical value of K (m)	Expt. value of I ($\text{kg}\cdot\text{m}^2$)	Theoretical value of I ($\text{kg}\cdot\text{m}^2$)
			t_1	t_2	t_3	t_4					

FURTHER CONSIDERATIONS

1. Calculate the length of the equivalent simple pendulum for one of the above observations by considering the time period of the simple pendulum to be equal to that of the compound pendulum.
2. Find the two values of h which satisfy the resulting quadratic equation giving equal vibration times.
3. Investigate, using the equation.

$$h^2 - hL_1 + K^2 = 0$$

the fact that if a distance K^2/h_1 is measured along the axis from G, remote from the point of suspension O to another point O', so that $OO' = L_1$ and the periodic time about O' is the same as that about O.

EXPERIMENT NO. 6 STUDY OF GYROSCOPE

OBJECTIVES

To determine the relation between the reaction torque and the precessional speed.

APPARATUS

Gyroscope, weights, hanger, stop watch.

THEORY

The change in the direction of the axis of spin of a Gyroscope is referred to as precession. A constant couple T (with axis parallel to Y) will produce a constant precessional speed, (around axis Z).

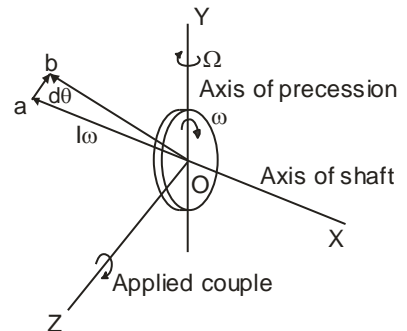

$$T = J\omega\Omega$$

For a uniformly rotating disk, ($\omega = \text{constant}$)

$$J\omega = \text{constant}$$

The couple has a proportional relationship with the precessional speed.

PROCEDURE

1. Connect the Gyroscope to 110 VAC supply. The disk will rotate and keep the axis horizontal.
2. Add weight on the shaft of the disk on one side. Note the weight (or applied couple). Measure the precessional speed by noting the time required by the disk to make 5 or 6 complete revolutions. Repeat 6 times with different loads gradually increasing the value.
3. Repeat the above procedure by applying loads on the other side of the shaft.
4. Plot the torque versus precessional speed curve. Check deviation of the experimental points from a straight line relationship and comment on the deviations, if any.

Load arm =

No. of obs.	Weight gm	Torque gm-cm	Time of precession sec	No. of revolutions	Precessional speed rad/sec
1.					
2.					
3.					
4.					
5.					
6.					

REFERENCES: Textbooks on Theory of Machines.

EXPERIMENT NO. 7 CRITICAL SPEED OF A SHAFT

OBJECTIVES

The objective of the experiment is to determine experimentally the critical speed of a transversely loaded rotating shaft and to compare it with the theoretically calculated value.

THEORY

In this exercise, only simply supported beam cases (bearings at two ends) are considered. It is known that the critical rotational speed in radians per second is equal to the circular natural frequency of transverse vibration. This statement is correct when concentrated masses are carried on shafts. For the case of an elastic system, if the spring constant is K then the natural frequency of vibration with mass m is given by-

$$\omega = \sqrt{K/m}$$

But $W = mg = Ky$, where y = static deflection.

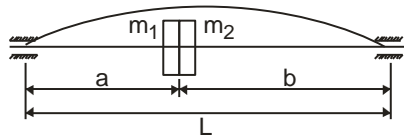

$$\text{Therefore, } \omega = \sqrt{\{(W/y) / (W/g)\}} = \sqrt{(g/y)} \text{ rad/sec} \quad (2)$$

Similarly, within the elastic limit for the case of a simply supported beam

$$\omega = \sqrt{(g/y)} \text{ rad/sec} \quad (3)$$

where, y = static deflection of the beam due to the weight W .

Therefore,

$$\begin{aligned} n_o &= \frac{60}{2\pi} \sqrt{\frac{g}{y}} \text{ rev / min} \\ &= \frac{30}{\pi} \sqrt{\frac{g}{y}} \text{ rev / min} \end{aligned} \quad (4)$$

where, g and y must be in consistent units.

Consider the following cases:

Case-1: (Refer to the figure shown above)

When the mass is not at mid-point, i.e., $a \neq b$, then the deflection of the shaft is given by-

$$y = \frac{Wa^2b^2}{3EIL}$$

When W is due to the masses m_1 and m_2 together.

Case-2: (Refer to the figure shown above)

When the mass is at the mid-point, i.e., $a = b$, then the deflection of the beam is given by-

$$y = \frac{WL^3}{48EI}$$

When W is due to the masses m_1 and m_2 together.

Case-3: (Refer to the following figures)

When the two masses are separate, Dunkerley's Formula for critical speed can be applied-

$$\frac{1}{n_c^2} = \frac{1}{n_{c1}^2} + \frac{1}{n_{c2}^2} \dots\dots\dots$$

where, $n_{c1} = \frac{30}{\pi} \sqrt{\frac{g}{y_1}}$ [when only m_1 is used]

$$n_{c2} = \frac{30}{\pi} \sqrt{\frac{g}{y_2}}$$
 [when only m_2 is used]

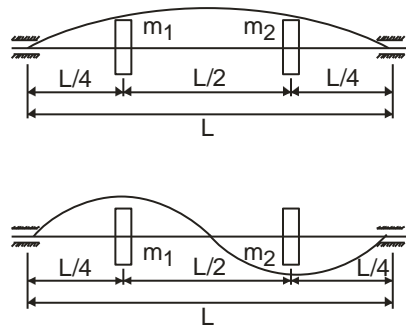

In this case, two critical speeds will be obtained. One speed can be found for the mode of the shaft as shown in the above figure (top). If the speed is further increased, the shaft will start rotating like that shown in figure (bottom) with a node at the centre. For this mode,

$$y = \frac{W(L/2)^3}{48EI}$$

NOTATIONS

- n_c = critical speed of the shaft (rpm)
- ω = critical speed of the shaft (rad/sec)
- d = diameter of the shaft (m)
- I = polar moment of inertia of the shaft (m^4)
- E = modulus of elasticity of the shaft material (for steel $E = 210 \text{ GN/m}^2$)
- L = length of the shaft (m) [NOTE: 25 mm should be deducted for each weight due to their stiffening effects on the shaft]
- y = deflection of the shaft due to the weights (m) [self weight of the shaft is neglected]
- W = weight of the attached mass (N)
- $m_1 = 1 \text{ kg}; \quad W_1 = 9.81 \text{ N}$
- $m_2 = 1 \text{ kg}; \quad W_2 = 9.81 \text{ N}$

APPARATUS

The Critical Revolution Machine, MT215, weights, scale and slide callipers.

ATTENTION

THE MAXIMUM DISTANCE BETWEEN THE TWO INNER BEARINGS IS 450mm. DISTANCE BETWEEN THE CONSECUTIVE MARKS ON THE SHAFT IS 50mm. BEFORE STARTING THE MACHINE, PLEASE CHECK THAT THE MASSES ARE TIGHTLY SCREWED ONTO THE SHAFT. ALSO MAKE SURE THAT THE INPUT VOLTAGE TO THE MACHINE IS 110V.

EXPERIMENTAL PROCEDURE

1. Set a suitable length L of the shaft by sliding the two block bearings along the shaft. The maximum length of the shaft should not exceed 400mm.
2. For Cases 1 and 2, the two masses should be brought together to obtain a punctiform mass. The masses are locked on the shaft by tightening the screws attached to them. *(The axially free bearings should be placed in such a way that a clearance of about 5 mm is obtained between the mass and the bearing. These bearings are used to prevent a greater than permissible deflection of the shaft).*
3. Connect the machine to 110V AC source. Make sure that the speed control knob is at the zero position before the machine is switched on. Increase the speed of the shaft by turning the speed control knob slowly and gradually. Make note of the speed from the dial when the critical speed is attained. Enter the value in the data sheet and compare the value with the theoretically calculated value. Repeat the procedure three times. One should take care about not to keep the speed of the shaft at its critical level for more than 2 seconds.

DATA AND RESULTS

Diameter of the shaft, $D = 6.0 \text{ mm}$

Polar moment of inertia of the shaft, $I = \frac{\pi}{64} D^4$

Format of the Table

Case-1: Two masses are together, but not at the mid point, $a \neq b$

No. of Obs.	Observed n_c (rpm)	Average n_c (rpm)	length of shaft, L (m)	Length a (m)	Length b (m)	Length y (m)	Calculated n_c (rpm)

Case-1: Two masses are together and at the mid point, $a = b$

No. of Obs.	Observed n_c (rpm)	Average n_c (rpm)	length of shaft, L (m)	Length a (m)	Length b (m)	Length y (m)	Calculated n_c (rpm)

Case-3: Two masses are separate

No. of Obs.	Observed n_c (rpm)	Average n_c (rpm)	length of shaft, L (m)	Length a (m)	Length b (m)	Length y (m)	Calculated n_c (rpm)
Without node							
With a node							

REFERENCES

Textbooks on Theory of Machine and Mechanical Vibrations (Chapters or sections on Critical Speed).

EXPERIMENT NO. 8 STUDY OF CAMS

OBJECTIVES

The objectives of the experiments are as follows:

1. To measure the displacement of the follower at different cam angles.
2. To plot the displacement versus cam angle curves, and
3. To compare the actual curves with the theoretical curves.

THEORY

(a) Rise with uniform motion:

The rise is given by-

$$Y = \frac{d}{\beta} \theta, \quad 0 < \theta < \pi$$
$$Y = -\frac{d}{\beta} \theta \quad \pi < \theta < 2\pi$$
(1)

where, d = maximum rise in inches

β = angle of cam displacement interval in radians

θ = cam angle in radians

Different values of θ is substituted into eqn. (1) to get the corresponding values of Y.

(b) Rise with constant acceleration and deceleration:

The displacement Y is given by:

$$y = 2d(\theta / \beta)^2; \quad \theta / \beta \leq 0.5$$
$$= d[1-2(1 - (\theta/\beta))^2]; \quad \theta/\beta \geq 0.5$$

With constant velocity, the angle of cam rotation is proportional to the time t.

(c) Simple harmonic motion

The displacement of the follower with simple harmonic motion is given by-

$$Y = \frac{d}{2} \left(1 - \cos \frac{\pi\theta}{\beta} \right)$$
(3)

where,

d = maximum rise in inches

β = angle of cam displacement interval in radians

θ = cam angle in radians

PROCEDURE

1. Place a cam on the shaft and screw on a follower on the follower rod.
2. Wrap a graph paper on the drum
3. Place a dial gauge on the horizontal support plate with its pointer on the follower attachment.
4. Rotate the cam shaft with the handle. The attached pencil will mark the displacement diagram on the graph paper. Take readings from the dial gauge at different cam angle.
5. Repeat procedure 1 to 4 with other cam and follower combinations.

DATA AND RESULTS

Format of the table

No. of Obs	Cam Angle (θ) Radians	Dial Gauge Reading Inches	Total Rise Angle (β) Radians	Maximum Rise (d) Inches	Theoretical Displacement		
					$Y = \frac{d}{\beta} \theta$ Inches	Constant Accel ⁿ & Decel ⁿ	Simple Harmonic
1							
2							
3							
4							
5							

REFERENCES

Textbooks on Theory of Machines Applied Kinematics.