

STRESS CONCENTRATION DESIGN FACTOR FOR BARS WITH SLOTS AND HOLES

Md. Atiqur Rahman Bhuiyan and Abu Rayhan Md. Ali

Department of Mechanical Engineering, Bangladesh University of Engineering & Technology
Dhaka, Bangladesh.

ABSTRACT

The stress concentration factors (SCFs) in the region of a slot (both axial and transverse) with semicircular ends and hole in square, circular and rectangular cross-sectioned bars have been investigated using the Finite Element (FE) method. Results are presented for axial loading and bending about Z-axis. The effects of the length and width of the slot and the radius and eccentric position of the hole on the magnitude and positions of the SCFs were investigated. The overall dimensions of bars were kept constant. The appropriate formulae of the nominal stresses for the concerned stress concentration factors (SCFs) were obtained. It is observed from the investigation that the stress-concentration factors (SCFs) are maximum for short slot length and width. Also, it is found that, stress-concentration factors (SCFs) due to axial loading are lower than those caused by most severe bending case.

Keywords: Stress concentration factor, Slotted bars, Eccentricity.

1. INTRODUCTION

The inclusion of slots in beams or bars may be a useful means of supporting the bar or locating the other structural elements relative to the beam or bar. The length and width of the slot and position of the hole relative to the cross-sectional dimensions of the bars can significantly affect the magnitude of the stress concentration factor (SCF) at the ends of the slot and hole. Although there was a lots of study about SCFs around any discontinuity in beams or bars [1-3] very little data are available for slots with semicircular ends. Hence a study of SCFs in square, circular and rectangular cross-sectioned bars was undertaken in order to understand the effect that the slot has on the stress distribution in the bar under different loading condition. A wide range of slot geometries has been investigated under bending (about z-axis) and axial loading condition.

SCF data are available in the literature for transverse circular holes in beams or bars [1-3, 4]. Again SCF data for transverse hole in a circular bar subjected to bending is also available in literature [5]. Results for thin plates with transverse holes [1] also exist. These results were useful for comparison with the Finite Element Results in order to validate the FE meshes and solution procedure. In the present study attempt was made to find the stress concentration factor in the region of slots (both axial and transverse) with semicircular end for axial loading and bending (about z-axis) conditions.

2. GEOMETRIES

For square and circular cross-sectioned bars the

overall dimensions of the bars are defined by the dimension, D , this is the length of the side of the square cross-sectioned bar or the diameter of the circular cross-sectioned bar. The dimensions of the slots are defined by the width, a , and the parallel length, b . The ends of the slots are circular (radius= $a/2$). The geometries are therefore fully defined by the geometric ratios a/D and b/D and most of the cases analysis were performed for slot with $0.2 \leq a/D \leq 0.8$ and $0 \leq b/D \leq 4$. Again, in case of bars having transverse slot, cross-sectional dimensions of the bar are defined by the dimension, W , this is the width of the bar, and D , is the thickness of the bar. The geometries are therefore fully defined by the geometric ratios a/D , b/D , b/a and b/W and most of the cases analysis were performed for slot with $0.2 \leq a/D \leq 0.8$ and $0 \leq b/D \leq 4$.

The geometries for bars having holes displaced from centerline are defined by the geometric ratios r/c ; r/d and e/c and analysis were performed for holes with $0.1 \leq r/c \leq 0.6$. Results were obtained for the axial loading and bending conditions. Geometries are shown in Figure 1 to 5.

3. FE MODELS

The FE models were generated using the solid 45 brick elements available in Ansys5.6 software [6] having the following material properties:

Young's modulus, $E=200$ GPa and Poisson's ratio= 0.3

All the analysis was done in free mesh condition. Particular care was taken to fine meshes where the stress concentration was expected to occur. The typical Finite

Element (FE) meshes are shown in figure 6.

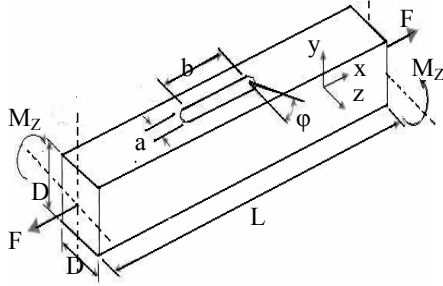

Fig 1. Square cross sectioned bar having axial slots, with different loading conditions

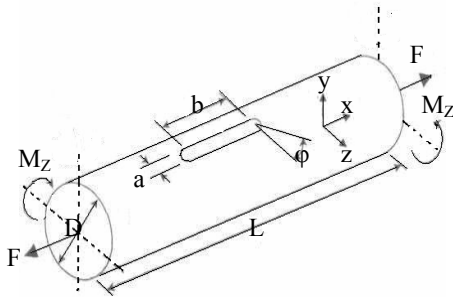

Fig 2. Circular cross sectioned bar having axial slots, with different loading conditions

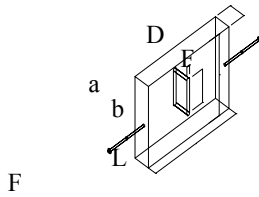

Fig 3. Rectangular bar with transverse slot, axial loading.

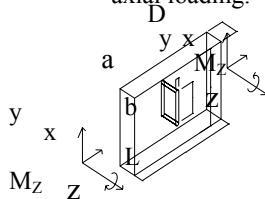

Fig 4. Rectangular bar with transverse slot, bending.

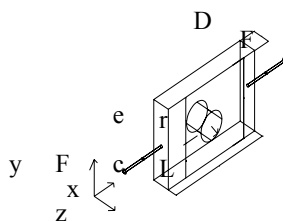
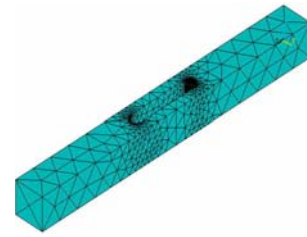
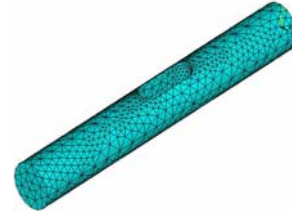

Fig 5. Rectangular bar with transverse hole, axial loading.



(a). Square bar with axial slot



(b) Circular bar with axial slot

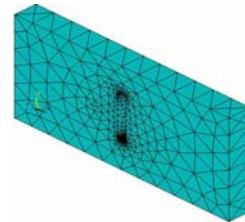

(c) Rectangular bar with transverse slot

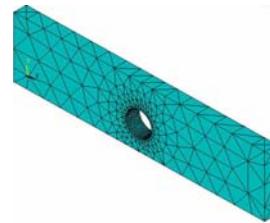

(d) Rectangular bar having hole displaced from centerline

Fig 6. Typical Finite Element (FE) Meshes

4. NOMINAL STRESSES

The nominal stresses σ_{nom} , used to define SCFs can be chosen in an arbitrary way. The nominal stress was chosen to be the average stress on the cross-section with minimum area i.e. the shaded sections of the bars given in figure-6. For the square cross-sectioned bar-

$$(\sigma_{nom}^a)_{square} = F/D*(D-a) \quad (1)$$

For circular cross-sectioned bar:

$$(\sigma_{nom}^a)_{circular} = 4F/D^2*(\pi-4a/D) \quad (2)$$

Where F is the axial load.

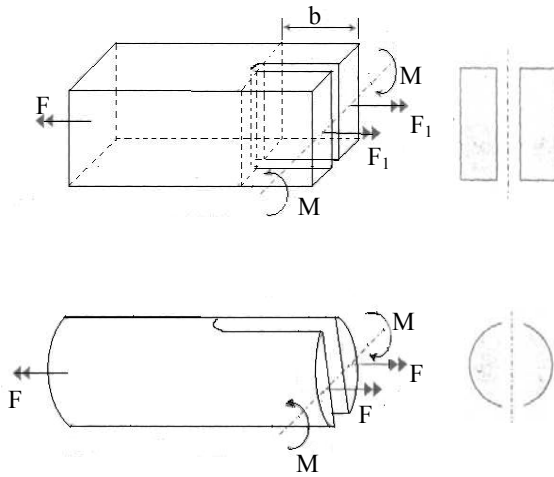

Fig 7. Free body diagram showing the tension and moment forces

Again, for square cross-sectioned bars

$$(\sigma_{nom}^{Mz})_{square} = 6 * M_z / D^2 * (D - a) \quad (3)$$

And for circular cross-sectioned bars:

$$(\sigma_{nom}^{Mz})_{circular} = [M_z / (\pi D^3 / 32 - a D^2 / 6)] \quad (4)$$

Where M_z are the bending moment about z-axis, and I_z is the second moment of area of the cross section of the bar about z-axis.

5. FINITE ELEMENT RESULTS

5.1 General Behavior

Surface stress contour plots for each of the loading cases for the square, circular and rectangular cross-sectioned bars are shown in Figure 8, 9, and 10. These are typical of those obtained for all slot lengths, widths and relative position of the holes. They indicate that for the loading cases (axial loading and bending about Z-axis) the peak stress occur at or near to the surface of the bar where the end of slot and holes is formed. The position of peak stresses is conveniently defined by the angular position, ϕ , defined in Fig-1 and Fig-2.

5.2 Axial Loading

The variations in SCF with b/D for the square, circular and rectangular cross-sectioned bar subjected to axial loading are shown in figs. 11(a) to 11(c). The same data are shown plotted as SCF vs. a/D for a range of b/D values including $b/D=0$, which corresponds to a circular hole, in figs 12(a) to 12(c). It can be seen that the SCFs for the square and circular cross-sectioned bars are particularly the same. Also, the SCFs are relatively independent of a/D ($0.2 \leq a/D \leq 0.8$) for any given value of b/D except $b/D=0$ for both square and circular bar. Again the variations in SCFs with b/D ($0 \leq b/D \leq 4$) are more significant particularly when $b/D < 1$. But in case of

Rectangular bar with transverse slot variations in SCFs is significant for both b/D and a/D values and maximum SCFs occurs within $b/D=1$ to $b/D=3$. Fig-13 shows another relations of SCFs with b/W for axial loading condition, which shows that variations in SCFs with b/W is same as with b/D .

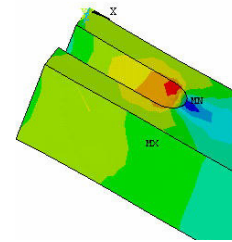

(a). Axial loading

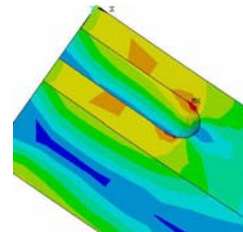

(b). Bending about Z-axis

Fig 8. Typical contours of a square cross-sectioned bar under different loadings.

The angular position ϕ , at which peak stress occurs under axial loading was found to be between 0° to 30° for all cases investigated and for square, circular and rectangular cross sections. The angle was found 0° for all cases with $b/D=0$ (i.e. circular holes) and generally increased with b/D and a/D for the range of geometries investigated.

5.3 Bending About Z-axis

The variations in SCF with b/D for the square, circular and rectangular cross-sectioned bar subjected to bending about z-axis are shown in figs. 14(a) to 14(c). The same data are shown plotted as SCF vs. a/D for a range of b/D values including $b/D=0$, which corresponds to a circular hole, in figs 15(a) to 15(c). As with the axial loading SCFs, it can be seen that the SCFs for the square and circular cross-sectioned bar are very similar to those for the case of bending about the z-axis. For square bar, the SCF is particularly independent of b/D for $b/D > 1$. However, for the circular bar the SCF is independent of b/D for a/D ($0 \leq a/D \leq 0.3$) except $b/D=0$. But, In Rectangular bar having transverse slot the SCFs increases with b/D . Fig-16 shows another relation of SCFs with b/W for bending about z-axis, which shows that variations in SCFs with b/W is same as with b/D .

The angular position ϕ , at which peak stress occurs under bending about Z-axis was found to be between 0° to 10° for all cases investigated and for square, circular and rectangular cross sections. The angle was found 0°

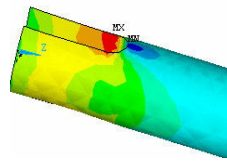

(a). Axial loading

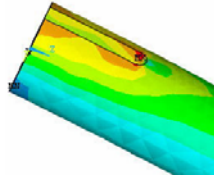

(b). Bending about Z-axis

Fig 9. Typical contours of a circular cross-sectioned bar under different loadings.

for all cases with $b/D=0$ (i.e. circular holes) and generally increased with b/D and a/D for the range of geometries investigated

5.4 Rectangular Bar with Hole in Tension

Variations in SCF for a flat bar in tension with a hole displaced from centerline is shown in fig.19 which shows that SCFs decreases with the increase of hole radius.

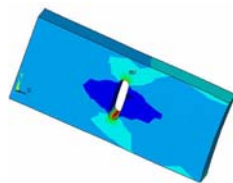

(a) Slotted bar in tension

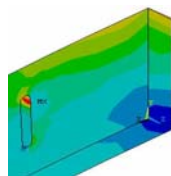

(b). Slotted bar in bending

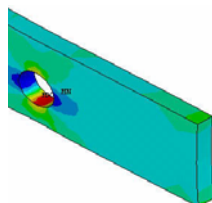

(c). Plate with a hole displaced from centerline

Fig 10. Typical contours of a rectangular cross-sectioned bar for axial loading conditions

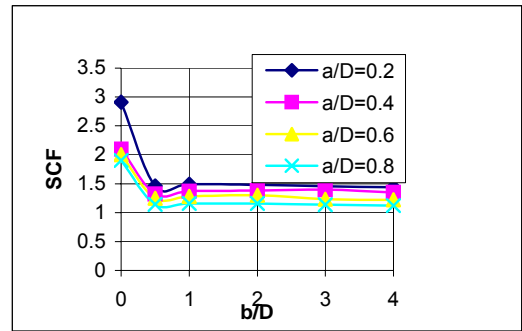

Fig 11(a). Variations in SCF with b/D for a range of a/D ratios for a square bar subjected to axial loading

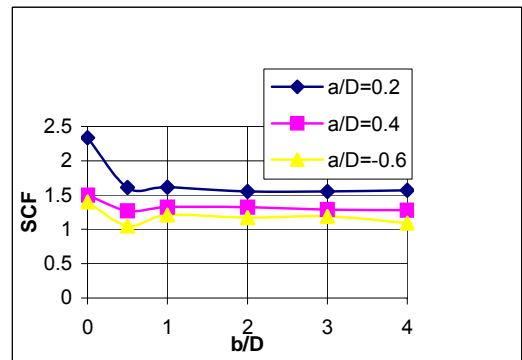

Fig 11(b). Variations in SCF with b/D for a range of a/D ratios for circular bar subjected to axial loading

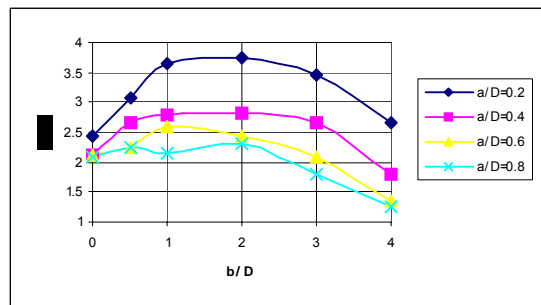

Fig 11(c). Variations in SCF with b/D for a range of a/D ratios for a slotted bar in tension.

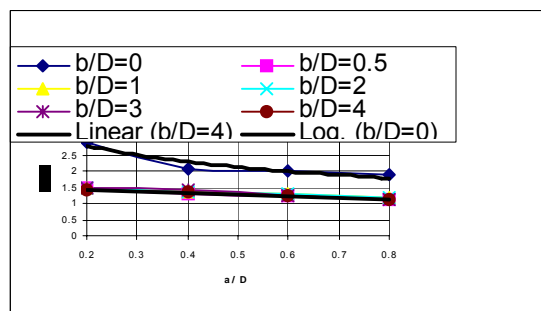

Fig 12(a). Variations in SCF with a/D for a range of b/D ratios for a square bar subjected to axial loading

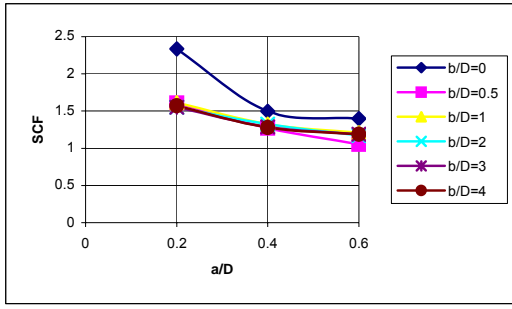

Fig 12(b). Variations in SCF with a/D for a range of b/D ratios for a circular bar subjected to axial loading

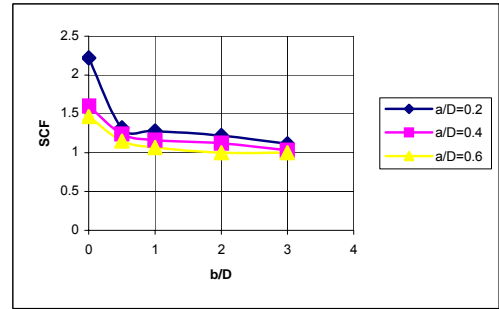

Fig 14(b). Variations in SCF with b/D for a range of a/D ratios for a circular bar subjected to bending about Z-axis

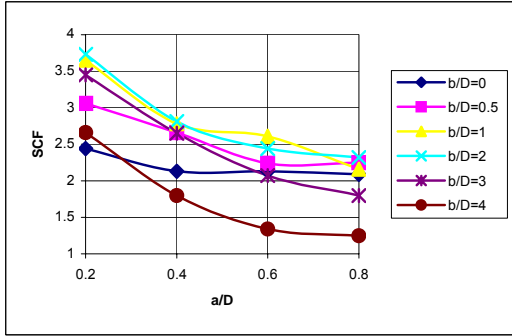

Fig 12(c). Variations in SCF with a/D for a range of b/D ratios for a slotted bar in tension.

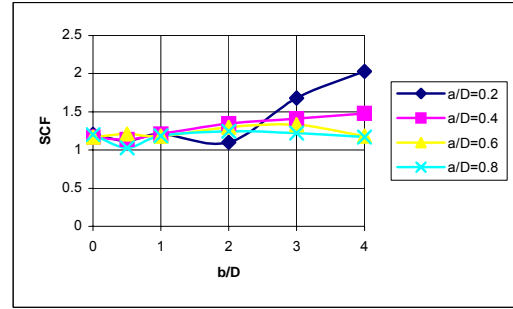

Fig 14(c). Variations in SCF with b/D for a range of a/D ratios for a slotted bar in bending.

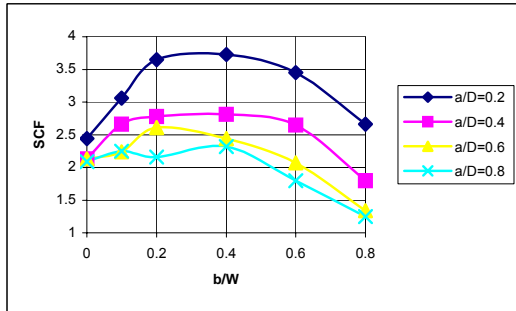

Fig 13. Variations in SCF with b/W for a range of a/D ratios for a slotted bar in tension

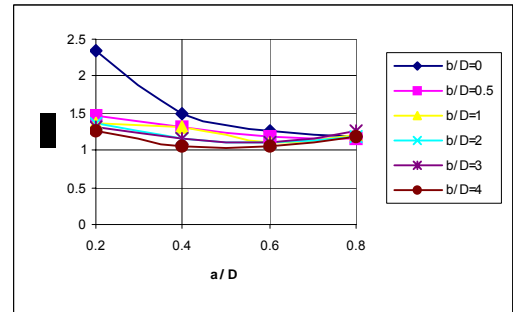

Fig 15(a). Variations in SCF with a/D for a range of b/D ratios for a square bar subjected to bending about Z-axis.

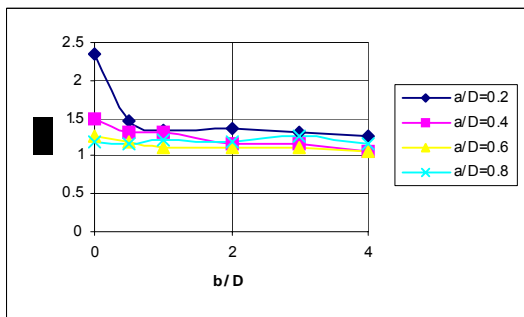

Fig 14(a). Variations in SCF with b/D for a range of a/D ratios for a square bar subjected to bending about Z-axis.

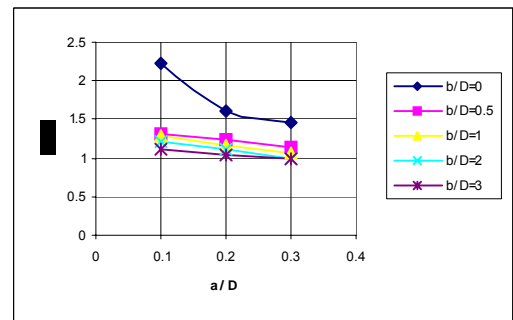

Fig 15(b). Variations in SCF with a/D for a range of b/D ratios for a circular bar subjected to bending about Z-axis.

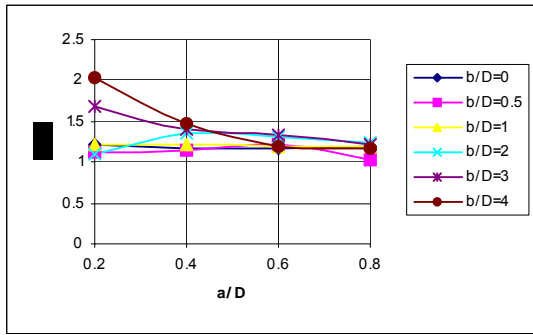

Fig 15(c). Variations in SCF with a/D for a range of b/D ratios for a slotted bar in bending

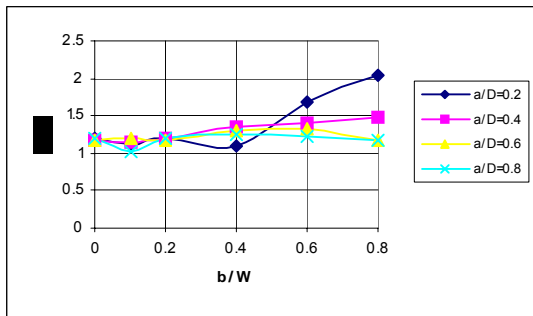

Fig 16. Variations in SCF with b/W for a range of a/D ratios for a slotted bar in bending

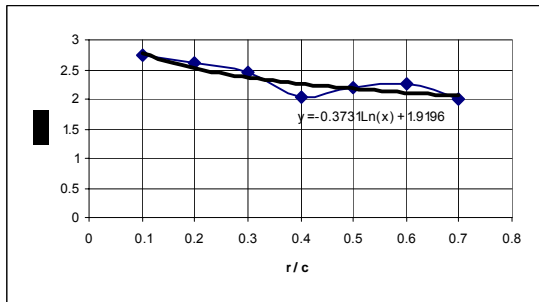

Fig 17. Stress Concentration Factor (SCF) for the Tension case of a plate with a circular hole displaced from centerline

6. CONCLUSIONS

A brief and comparative study about Stress concentration factor (SCF) for square, circular and rectangular cross-sectioned bars having slots and holes has been done. So, the following conclusion may be drawn in regard to the above study,

- i. For axial loading, SCFs are relatively independent of large b/D values (when b/D is greater than 1) for both square and circular cross-sectioned bars whereas the effect is more significant for rectangular bars with transverse slot.
- ii. For bending about Z-axis, SCFs are independent of b/D after b/D=0.5 for both square and circular bars.
- iii. For Rectangular bar in bending, SCFs increases with the increase of b/D.
- iv. For flat bar having holes displaced from centerline SCFs decrease slightly with the increase of radius of hole.

7. REFERENCES

1. R. E. Peterson, 1974, *Stress Concentration Factors*, John Wiley & Sons, New York.
2. R. E. Peterson, 1951, " Design Factors for Stress concentration," *Machine Design*, vol. 23, no.2, p. 161; no.5, p. 159; no. 6, p. 173; no.7, p. 155;.
3. R.E. Peterson, 1953 (Fifth Printing, August, 1966), "*Stress Concentration Design Factors*", John Wiley & Sons, Inc., New York.
4. Joseph E. Shigley & Charles R. Mischke, 1986, *Standard Handbook of Machine Design*, McGraw Hill, Chapter-12.
5. Perry, 1976, *Engineering Manual*, Third Edition, Section-8, p. 8-24.
6. ANSYS/Standard User's Manual, Version 5.6.

8. NOMENCLATURE

Symbol	Meaning	Unit
a, b	Width and length of parallel section of the slot	(m)
A	Area	(m ²)
D	Width or diameter of the bar	(m)
E	Young's modulus	(N/m ²)
ν	Poisson's ratio	(m/m)
F	Axial load	(N)
I, I_z	Moment of inertia	(m ⁴)
K_t, SCF	Stress concentration factor	(-)
L	Length of the bar	(m)
M	Bending moment	N.m
r	Radius	(m)
t	Thickness	(m)
x, y, z	Co-ordinates	(-)
σ, σ_{nom}	Stress and nominal stress respectively	(N/m ²)
σ_a	Uniform axial stress (axial load)	(N/m ²)
ϕ	Angular position around the end of the slot	(degree)
c	Distance from edge	(m)
e	Eccentricity	(m)