

## DESIGN AND CONSTRUCTION OF A MUFFLER FOR ENGINE EXHAUST NOISE REDUCTION

M. Rahman, T. Sharmin, A F M E. Hassan, and M. Al Nur

Department of Mechanical Engineering  
Bangladesh University of Engineering and Technology, Dhaka 1000, Bangladesh

### ABSTRACT

An inherent drawback of IC engines is that it is a major source of noise pollution. That is why the reduction of exhaust noise from engines is, now-a-days, an important issue. Attaching a muffler in the exhaust pipe is the most effective means of reducing noise. But muffler requires specific design and construction considering various noise parameters produced by the engine. In our country, the conventional design does not include much of a parametric noise analysis or other engine characteristics. A muffler for stationary petrol engine has been designed and manufactured. The performance characteristics, i.e. noise reduction capability of the muffler, has been tested and compared with that of the conventional muffler. The result has been found to be quit satisfactory.

**Keywords:** Muffler, Engine exhaust noise reduction, Design

### 1. INTRODUCTION

Internal combustion engine is a major source of noise pollution. These engines are used for various purposes such as, in power plants, automobiles, locomotives, and in various manufacturing machineries. Noise pollution created by engines becomes a vital concern when used in residential areas or areas where noise creates hazard. Generally, noise level of more than 80 dB is injurious for human being. The main sources of noise in an engine are the exhaust noise and the noise produced due to friction of various parts of the engine. The exhaust noise is the most dominant. To reduce this noise, various kind of mufflers are usually used. The level of exhaust noise reduction depends upon the construction and the working procedure of mufflers.

Engine makers have been making mufflers for more than 100 years. As the name implies, the primary purpose of the muffler is to reduce or muffle the noise emitted by the internal combustion engine. Muffler technology has not changed very much over the past 100 years. The exhaust is passed through a series of chambers in reactive type mufflers or straight through a perforated pipe wrapped with sound deadening material in an absorptive type muffler. Both types have strengths and weaknesses. The reactive type muffler is usually restrictive and prevents even the good engine sounds from coming through, but does a good job of reducing noise. On the other hand, most absorptive type mufflers are less restrictive, but allow too much engine noise to come through. Regardless of the packing material, absorptive type mufflers tend to get noisier with age.

Most recently, automotive engineers have been

experimenting with electronic noise suppression muffler. A sound pressure wave,  $180^\circ$  out of phase, is generated by an electronic device to cancel out a similar sound wave generated by the engine. It is an effective way of cancelling noise without restricting the flow. Unfortunately, it is too costly and currently impractical for most of today's engines. However, out of phase sound wave cancellation is the best technology so far to control engine noise.

Now-a-days, this  $180^\circ$  phase sound is created within the engine muffler by reflecting the out-going sound waves. This reflected sound is used to attenuate the main noise. This procedure is called reflective noise cancellation system. Using a resonator sometimes does this.

### 2. ENGINE NOISE

Pulses released by the exhaust is the cause of engine noise. When the expansion stroke of the engine comes near the end, the outlet valve opens and the remaining pressure in the cylinder discharges exhaust gases as a pulse into the exhaust system. These pulses are between 0.1 and 0.4 atmosphere in amplitude, with pulse duration between 2 and 5 milliseconds. The frequency spectrum is directly correlated with the pulse duration. The cut-off frequency lies between 200 and 500 Hz. Generally, engines produce noise of 100 to 130 dB depending on the size and the type of the engine.

### 3. MUFFLER SELECTION

In order to select a suitable muffler type, some basic information are necessary regarding how industrial

mufflers work. Industrial mufflers, (and mufflers in general), attenuate noise by two fundamentally different methods. The first method, called reactive attenuation - reflects the sound energy back towards the noise source. The second method, absorptive attenuation - absorbs sound by converting sound energy into small amounts of heat. There are three basic industrial muffler types that use these methods to attenuate facility noise - reactive silencers, absorptive silencers and anyone or both of them combined with resonator.

The proper selection of a muffler is performed by matching the attenuation characteristics of the muffler to the noise characteristics of the source, while still achieving the allowable muffler power consumption caused by muffler pressure drop. Fortunately, industrial noise sources separate primarily into three different categories with specific characteristics.

The first category covers sources that produce mainly low-frequency noise, yet can typically tolerate relatively high-pressure drops. Engines, rotary positive blowers, reciprocating compressors, and rotary screw compressors are types of these sources. It is simply the nature of these machines to produce low-frequency noise and have pressure-volume relationships that are quite tolerant of system pressure drop. These machines are perfectly suited for reactive (chambered) silencers.

The second category of noise sources are those that produce mainly high-frequency noise and have performance that is very sensitive to system pressure losses. These sources are almost always moving or compressing a fluid with spinning blades. Examples include centrifugal fans, compressors, and turbines. By definition, this type of equipment is best treated with absorptive silencers for both low and higher temperature applications.

Resonators can be used to remove tones from the exhaust spectrum.

There are two major industrial facility applications that fall outside these categories, and are best silenced with specific combination reactive-absorptive mufflers. These sources are high-speed rotary positive blowers and high-pressure vents. Both sources have substantial high and low frequency noise content, and can tolerate moderate pressure drop. As a general rule, reciprocating or positive displacement machines should be attenuated with reactive silencers, and centrifugal equipment should use absorptive silencers. For all remaining major noise sources, combined reactive-absorptive silencers are appropriate with many designs available to choose from.

### 3.1 Exhaust Muffler Grades

Muffler grades:

Industrial/Commercial:

IL = 15 to 25 dBA

Body/Pipe = 2 to 2.5

Length/Pipe = 5 to 6.5

Residential Grade:

IL = 20 to 30 dBA

Body/Pipe = 2 to 2.5

Length/Pipe = 6 to 10

Critical Grade:

IL = 25 to 35 dBA

Body/Pipe = 3

Length/Pipe = 8 to 10

Super Critical Grade:

IL = 35 to 45 dBA

Body/Pipe = 3

Length/Pipe = 10 to 16

IL= Insertion Loss, i.e., the level of sound reduction after attaching the muffler.

The super-critical grade muffler generally represents the “top of the line” for reactive mufflers. Fig. 1 below shows a 3-chamber critical grade muffler. It achieves its “super-critical” status primarily from its length, as much as 16x pipe diameter.

Fig. 1 shows the approximate insertion loss as a function of frequency for the various grades of mufflers. All values are approximate since no muffler has repeatable IL performance from engine to engine. It can be noted that the IL performance of the absorptive silencer is the best in the frequency region where reactive mufflers start to deteriorate.

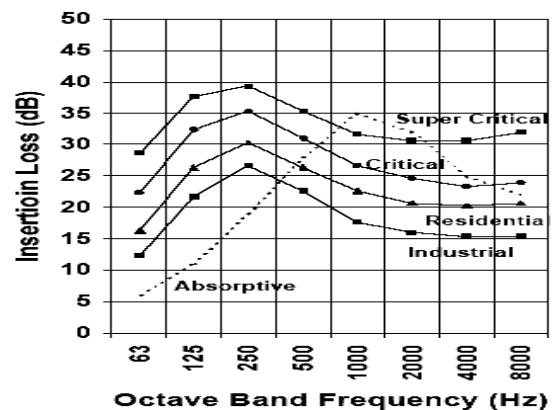

Fig 1. Insertion loss (dB) versus frequency (Hz) curve [1]

## 4. DESIGNING AND CALCULATION OF MUFFLER

A muffler have been designed which is of supercritical grade type and includes all the three attenuation principles i.e., reactive, followed by absorptive type muffler, and a side branch resonator. The interesting events of the design are continuous volume reduction of chambers in the reactive part, the flow pipe cross-sectional area is maintained constant throughout, a layer of insulation outside the reactive part, the placing of side branch resonator compactly, option for tuning the resonator using a screw and cylinder.

### 4.1 Design Data

For the experiment, an existing petrol engine has been used. Calculations are done on the basis of data collected from the engine; however, some data are applicable to all engines. For designing, the following data are required.

1. Sound characteristics (Without silencer)

Rpm of the engine= 2026

	Load	Sound level
Without any load	9.2 kg	104.5 dbA
50% load	15 kg	106.5dbA
100% load	24 kg	107dbA

2. Sound analysis with frequency analyzer (to obtain the dominating frequency)

Two dominating frequencies, the low level and the high level have been obtained. These are:

Frequency Level	Frequency (Hz)
Low	270
High	40000

3. Diameter of exhaust pipe of engine/inlet pipe of muffler

The Exhaust Pipe diameter: 1.5 inch

4. The theoretical exhaust noise frequency range

From various experiments it has been found that the theoretical exhaust noise frequency is 200-500Hz.

4.2 Reflective Part Design

S<sub>1</sub> = Exhaust pipe diameter = 1.5 inch

The dimensions to determine are that of the chamber length L and the body diameter S<sub>2</sub>.

To determine L, three methods have been used. They are as follows:

1. First method used to determine L

Maximum attenuation occurs when  $L = n\lambda/4 \dots (1)$

where,  $\lambda$  = wavelength of sound (m or ft)

$n = 1, 3, 5, \dots$  (odd integers)

Since  $\lambda$  is related to frequency by the speed of sound, one can say that the peak attenuation occurs at frequencies which correspond to a chamber length.

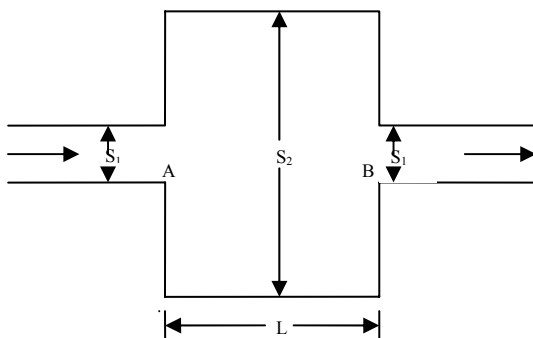

Fig 2. Schematic of a muffler showing various dimensions

The range of frequency is obtained from the design data in section 4.1. The following table of L has been constructed with this data.

Table 1: Calculated wavelength from frequencies

Frequency	$\lambda = C/f$ (m)	$\lambda$ (inch)	n = odd integer	L (inch) $L = n\lambda/4$
N(min)	1.65	67.2	1	16.8
200 Hz	$(\lambda_{max})$	$(\lambda_{max})$	3	50.4
n(max)	0.66	26.9	1	6.72
500 Hz	$(\lambda_{min})$	$(\lambda_{min})$	3	20.16

From Table 1, one can find that L has a range between 6.72 and 50.4 inch.

Due to space limitation, the length of the small chamber has been chosen to be 6.72 inch and 20.16 or 20 inch for the whole of the three chambers.

2. Range of chamber length considering the temperature of exhaust gas

Another factor which must be considered in expansion chamber design is the effect of high temperature of exhaust gases. This factor can easily be included in the design by using the following equation:

$$0.5(49.03\sqrt{^{\circ}R})/2\pi f \leq L \leq 2.6(49.03\sqrt{^{\circ}R})/2\pi f \quad (2)$$

where,  $\sqrt{^{\circ}R}$  = absolute temperature of the exhaust gas  
f = frequency of sound (Hz)

Let the temperature of exhaust is assumed to be 300° F or 759.7° R

Putting this value in equation (2), one obtains,

$$0.5(49.03\sqrt{759.7})/2\pi 270 \leq L \leq 2.6(49.03\sqrt{759.7})/2\pi 270$$

(here, f = 270Hz for low frequency reactive muffler)

$$0.4 \text{ ft} \leq L \leq 2.04 \text{ ft}$$

From the 1st method, L = 20 inch = 1.67 ft.

So the condition of  $0.4 \text{ ft} \leq 1.67 \leq 2.04 \text{ ft}$  is satisfied.

3. Range of chamber length according to ASHRAE Technical Committee 2.6

According to ASHRAE Technical Committee 2.6 [2], muffler grades and their dimensions, the requirement matches with the super critical grade.

$$IL = 35 \text{ to } 45 \text{ dBA}$$

$$\text{Body/Pipe} = 3$$

$$\text{Length/Pipe} = 10 \text{ to } 16$$

That is,  $10 \times \text{pipe dia} \leq L \leq 16 \times \text{pipe dia}$

$$10 \times 1.5'' \leq L \leq 16 \times 1.5''$$

$$15'' \leq L \leq 24''$$

Again the chosen length L = 20 inch, satisfies the above condition.

### Body diameter ( $S_2$ )

According to ASHRAE Technical Committee 2.6

$$\begin{aligned} \text{IL} &= 35 \text{ to } 45 \text{ dBA} \\ \text{Body/Pipe} &= 3 \end{aligned}$$

That is, body diameter,  $S_2 = 3 \times 1.5'' = 4.5$  inch.

A standard body diameter of 6.5 inch for UR Series with length 20 inch [1] has been taken. Considering the above mentioned values and outside glass wool insulation,  $S_2$  has been chosen as 6 inch.

### Other parts of reactive muffler design

It has always been considered that the flow path diameter does not reduce at any point. Otherwise, there would be a possibility of back pressure. That is why, the following equation has been used to determine the diameter of the smaller pipes, which are at the outlet of the first two chambers.

$$\pi S_1^2/4 = \pi d_1^2/4 + \pi d_2^2/4$$

where,  $d_1$  and  $d_2$  are smaller pipe diameters.

As both pipes are of the same diameter, one gets,

$$d_1 = d_2 = 1.06 \text{ inch} \approx 1 \text{ inch.}$$

Now, the total length  $L$  has been divided into three small chamber lengths  $L_1$ ,  $L_2$ , and  $L_3$ .

As the pressure is dropping from the first chamber to the next, we reduced the length slightly from the first to the third.

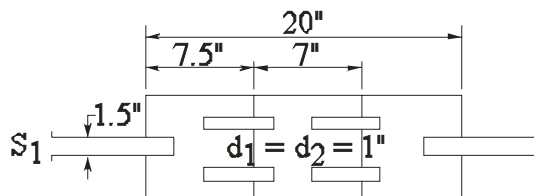

Fig 3. A simple layout of reactive muffler with dimensions

According to the value shown in Table 1, the minimum  $L$  can be 6.72 inch  $\approx$  6.5 inch.

So, the values of  $L_1$ ,  $L_2$ , and  $L_3$  are chosen to be 7.5 inch, 7 inch, and 6.5 inch respectively, as the gases gradually face reduced space or volume.

### 4.3 Absorptive Part Design

The absorptive muffler is the classic dissipative design, deriving its noise control properties from the basic fact that noise energy is effectively “absorbed” by various types of fibrous packing materials. That is, as the sound waves pass through the spaces between the tightly packed, small diameter fibers of the absorptive material, the resulting viscous friction dissipates the sound energy as small amounts of heat.

Absorptive mufflers are highly effective on high-frequency noise (1000-8000 Hz). At frequencies above and below this range, attenuation performance

progressively diminishes with common absorptive materials unless special design considerations are implemented. Since noise is absorbed by the acoustic packing media, absorptive mufflers generally employ straight-through or annular internal designs, which impose very little restrictions on air flow. Typically, the greater the ratio of packing surface area to flow area, the greater is attenuation capability of the silencer. Many different packing materials can be used in absorptive silencers and are chosen for use based on varying absorptive performance, price, temperature and corrosion characteristics.

The effect of the thickness of absorptive material and spacing play an important role in sound attenuation. The attenuation increases sharply at high frequencies as the spacing is narrowed. Better performance at lower frequency is obtained as the thickness of the absorbing material is increased.

In order to attenuate high frequency noise, a metal tube surrounded by acoustical-quality mineral wool inside the muffler outer containment shell has been used here. The sides of the tube are perforated that permit sound waves impinge on the absorbing materials. The same dimensions as that in the reflective type have been used here. It should be noted that ASHRAE TC 2.6 is also applicable for absorptive type.

### 4.4 Resonator Design

Resonators are used to attenuate low frequency noise. The principle is to create an opposite phase waveform to nullify each other. The simplest way to produce a wave of opposite phase is to put a reflective obstacle at a distance of  $n\lambda/4$ , where  $n = 1, 3, \dots$  other odd integers. A value of  $n = 1$  has been used in the design.

A tunable resonator has been designed. By moving a screw, a cylinder comes closer or goes away from the close end of the resonator. As a result, the length of the resonator increases or decreases. The range of length has been determined in the following way.

The velocity of sound increases 0.6m/sec with an increase in temperature of 1° C. The velocity of sound at 0° C is 332 m/sec. For the design purpose, the minimum temperature has been assumed to be 20° C and the maximum to be 300° C.

From section 4.1, the dominating frequency for low range is obtained to be 270 Hz. The range from 220 to 330 Hz has been chosen here. A table has been constructed with various combinations to get the minimum and the maximum wavelengths, which can cover the above range.

Table 2: Length of the resonator for various frequencies

Temp °C	Vel (C) m/sec	f (freq.) Hz	$\lambda$ (m) $\lambda = C/f$	$\lambda$ (inch)	L(inch) $L = \lambda/4$
(max) 20°C	(max) 344	(max) 330	(min) 1.04	(min) 41.04	10.24
(min) 300°C	(min) 512	(min) 220 (max) 330 (min) 220	(max) 1.56 (min) 1.55 (max) 2.33	(max) 91.73	22.93

From Table 2,  $L_{max}$  and  $L_{min}$  have been found to be 22.93 inch, i.e., 23 inch and 10.24 inch or 10 inch, respectively.

So, a cylinder of length  $L_{cyl} = L_{max} - L_{min} = 23'' - 10'' = 13$  inch has been chosen. With two nuts at the ends, the total length comes out to be 14 inch.

Thus the total resonator length becomes,

$$L_{res} = L_{max} + L_{cyl} + \text{clearance for lubrication} \\ = 23'' + 14'' + 0.75'' = 37.75 \text{ inch.}$$

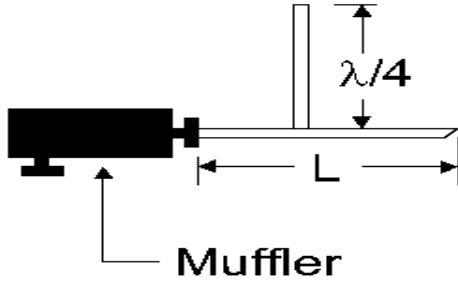

Fig 4. Schematic of the resonator

#### 4.5 Tailpipe Design

According to equation (1), resonance occurs when  $L = n\lambda/2$ . So, for an economical construction, the value of  $n$  may be taken as 1. Then the tailpipe must be less than  $\lambda/2$ .

The resulting muffler is shown in figure 4 and fig 5.

### 5. RESULTS AND DISCUSSION

The results from various tests are tabulated below:

Table 3: Sound characteristics (without silencer)  
Rpm of the engine = 2026

	Load	Sound level
Without load	9.2 kg	104.5 dbA
50% load	15 kg	106.5dbA
100% load	24 kg	107dbA

Table 4: Sound characteristics (with existing silencer)  
Rpm of the engine= 2030

	Load	Sound level
Without load	8.6 kg	92 dbA
50% load	15.8 kg	93 dbA
100% load	25.5 kg	97 dbA

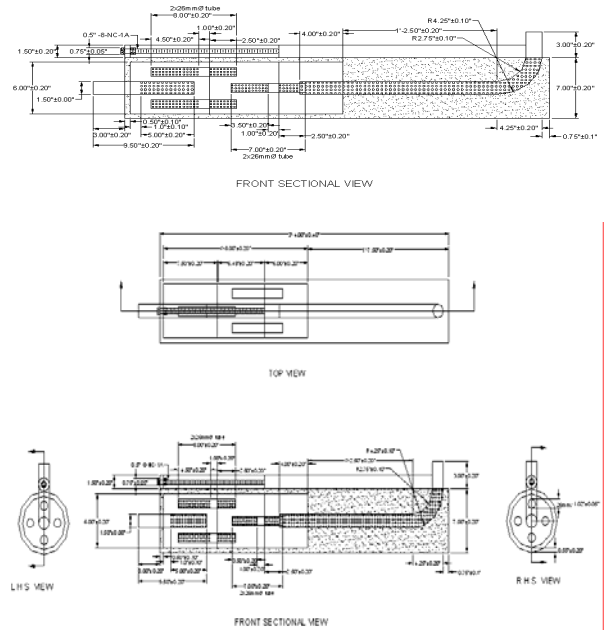

Fig 5. Two-dimensional view of the designed muffler

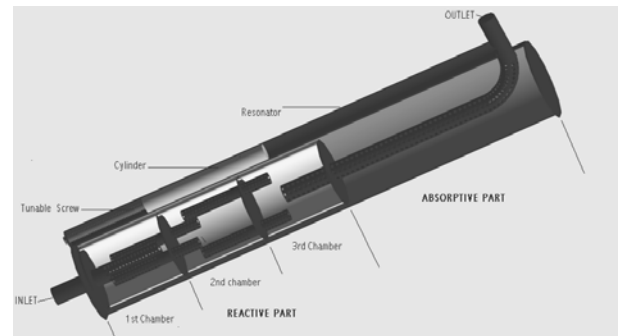

Fig 6. Three-dimensional cut view of the muffler

Table 5: Sound characteristics (with designed silencer)  
Rpm of the engine= 2026

	Load	Resonator position (Effective length)	Sound level (dBA)	Difference between attenuation due to resonator tuning (dBA)
Without load	9.2 kg	min	80	2
		max	82	
50% load	15 kg	min	81	1.5
		max	82.5	
100% load	24 kg	min	83	1
		max	84	

Table 6: Sound attenuated, insertion loss (with designed silencer at tuned position)

	Load	IL, Sound attenuated
Without load	9.2 kg	24.5 dbA
50% load	15 kg	25.5 dbA
100% load	24 kg	24 dbA

### 5.1 Effect of Load on Resonator Tuning

From Table 5, the following graph has been constructed.

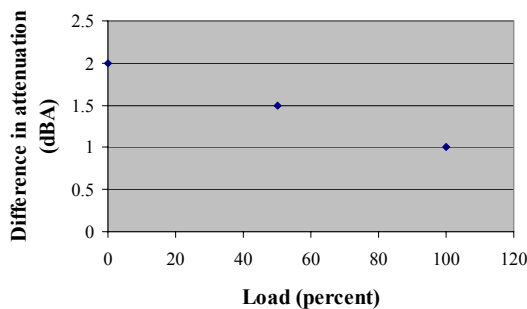

Fig 7. Difference in attenuation due to tuning at different loads

One can see that, at lower load, the difference between attenuation due to resonator tuning is higher. This means that at lower load it works better. The reason may be that, at higher load there are a lot of different sound waves created that have different wavelengths than those for which the resonator has been designed.

The designed muffler attenuates about 25dBA, making it a critical grade muffler and is significantly better than the earlier one.

### 6. CONCLUSIONS

From the above discussions, the following conclusions can be drawn:

1. The muffler is capable of attenuating noise by about 25 to 35 dBA.

2. The muffler is designed to attenuate both high and low frequency noises.
3. There is a side branch resonator, which attenuates residual low frequency noise.
4. There is an option of tuning the resonator, which makes the muffler flexible to use with different engines.
5. The conventional design of side branch resonator construction involves the resonator connected perpendicularly to the tail pipe, but in the present design, the resonator is parallel to the main body of the muffler. This makes the muffler usable with engines having limited space.
6. The reactive portion of the muffler has been covered with a layer of absorptive material which considerably decreases the self generated noise of the muffler.
7. The material used in the muffler is capable to withstand temperature of higher order.

The resonator works pretty well between a sound frequency of 220 Hz and 330 Hz, so if the residual frequency exceeds the range, the resonator becomes largely ineffective.

Although the muffler has been designed for stationary engines, it can be used in the automotive exhaust with minor modifications.

### 7. REFERENCES

1. Bell, L.H., 1982, Industrial Noise Control, Marcel Dekker, Inc, New York.
2. Lilly, J.J., "Engine Exhaust Noise Control", ASHRAE Technical Board 2.6.
3. Miers, S.A., and R.D. Chalgren, "Noise and Emission Reduction", SAE Technical Paper Series 2000-01-2573.
4. CORSA Performance, 2004, "Reflective Noise Cancellation", Power Pulse RSC Technology.
5. Crouse, W.H. and D.A. Anglin, 2003, *Automotive Mechanics*, 10<sup>th</sup> Edition, McGraw-Hill, New York.

### 8. ACKNOWLEDGEMENT

This research is an outcome of the undergraduate project and thesis done in the Department of Mechanical Engineering, BUET during the period 2004 – 2005.